



The Design and Construction of A Dynamic Multi-Sensor and Multi-Storage Data Logger for Weather Parameters

Retno Tri Wahyuni*, Heri Subagiyo, Amirul Huda

Electronics System Engineering Study Program, Politeknik Caltex Riau, Indonesia

Received 11 October 2023 | Accepted 24 November 2023 | Published 30 November 2023

DOI: <https://doi.org/10.37859/jp.v14i1.6278>

Keywords:

Data logger;
ESP32;
Weather
parameter;
SD card;
Database

Abstract. The Data Logger is an electronic device designed to automatically and continuously store data. Data loggers are widely used in various fields, including the storage of weather parameter data. Generally, a data logger consists of sensor devices, a processor, and storage media. This paper discusses the design of a dynamic data logger that allows the selection of sensor input types and storage media such as an SD card or a cloud database. The data logger comprises hardware devices, including five weather parameter sensors, a processor and a communication module using ESP32, a timing system using RTC, and local storage media in the form of an SD card. Additionally, there is a computer-based user interface built using Visual Basic. The connection between the user interface application and the data logger hardware is established using serial communication. Overall system testing results indicate that all features of the data logger system have operated well.

*Corresponding author.

E-mail address: retnotri@pcr.ac.id

©2023 by The Author(s). Published by LPPM Universitas Muhammadiyah Riau

This is an open access article under the CC BY-NC-SA license

(<https://creativecommons.org/licenses/by-nc-sa/4.0>).

1. Introduction

A data logger is an electronic device designed to automatically store or record data from various measuring instruments over a specific period. The purpose of constructing a data logger is to achieve accurate data collection continuously without direct human intervention. Characteristics of a data logger include integrated sensors, an automatic data recording device, storage media, power supply systems, and interfaces for configuration. Additionally, data loggers are typically designed to be portable for easy transportation and relocation.

The application of data loggers can be found in various fields, such as the environment, agriculture, industry, transportation, and so on. In the environmental sector, data loggers are utilized for observing environmental conditions both indoors and outdoors, as developed by Ali et al. (2016) and Bhadola et al. (2022), as well as weather observations (Mabrouki et al., 2021). Applications in agriculture can be encountered in works by Spinelli & Gottesman (2019) and Curasi et al. (2022). This is followed by Irfan Bin Edi et al. (2022) and Yadav & Sakle (2023) developing data loggers for observing variables in-vehicle systems. Meanwhile, Singh & Thakur (2019) have developed data logger applications for energy generation, especially solar energy.

One of the essential types of data is weather parameters. The benefits of this data are commonly used for weather forecasts, predicting suitable planting times, forecasting for initiating activities in mining, and many other applications. Some frequently observed weather parameters include temperature, humidity, light intensity, rainfall, wind direction, and wind speed. Weather parameter data is typically required in the form of daily, monthly, and yearly data.

Data loggers use a microprocessor as the processing and control unit, internal memory for data storage, and one or more sensors to collect data. Generally, data loggers are devices powered by batteries as a power source. In short, a data logger is a microprocessor-based system equipped with memory, sensors, and a power source. With technological advancements, alongside being microprocessor-based, data loggers have also evolved to be based on microcontrollers, minicomputers, or even Field-Programmable Gate Arrays (FPGA).

Computer-based data loggers, such as those built on the Raspberry platform, can be found in studies conducted by Pasquali et al. (2017), Clement et al. (2020), and Bhadola et al. (2022). ATmega-based data loggers have been developed by Sadli, 92020), while Mahzan et al. (2017), Spinelli & Gottesman (2019), Mabrouki et al. (2021), Matkar et al. (2022), and Yadav & Sakle (2023) have developed Arduino-based data loggers.

If cost is a crucial factor in the development of a data logger, then choosing a microcontroller-based platform is the most suitable option. Therefore, the development of low-cost data loggers often involves the use of microcontrollers or microcontroller system module boards, as seen in works by Ali et al., (2016), Spinelli & Gottesman (2019), Bhadola et al. (2022), and Yadav & Sakle (2023). Data from sensors installed on the data logger is typically stored in a memory also integrated into the data logger, for example, using SD-card modules as in Bayhan et al. (2021) or, alternatively, it can be wirelessly transmitted to a database server either using specific network protocols or employing Internet of Things (IoT) technology, as demonstrated in Spinelli & Gottesman (2019), Samkria et al. (2021), and Mabrouki et al. (2021).

This paper will discuss the design of a low-cost dynamic data logger with multi-sensor and multi-storage capabilities. The data logger is considered dynamic due to the configuration features for sensor and storage media selection. The configuration process is carried out through an interface built on a computer device. Available sensor types include temperature, humidity, light intensity, rainfall, wind speed, and wind direction. The storage media options include an SD card and cloud storage. The focus of this paper is on the design of the data logger system and the testing of its features, excluding sensor testing.

2. The Methods

Dynamic data loggers with multi-sensors and multi-storage generally consist of sensor devices, a processor, a communication module, a data storage system, a timing system, a power supply system, and a computer-based interface application for configuration. The overall system block diagram can be viewed in Figure 1.

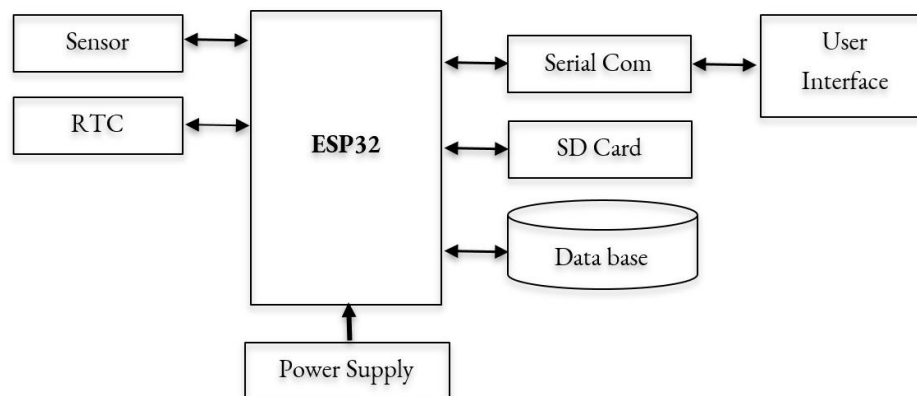

Figure 1. Block diagram system of data logger

In the data logger system, the sensor devices consist of five types: temperature and humidity sensors using DHT11, light intensity sensors using BH1750, rainfall sensors, and wind speed and direction sensors using a weather station kit from DFRobot. The processor used in the data logger system is an ESP32 module, which also functions as the communication module. The use of the ESP32 module impacts a more compact and portable design due to its small size. Through this ESP32 module, data can be sent to the database according to the configuration results.

Furthermore, the timing system used is the DC3231 type RTC (Real-Time Clock). The data storage device on the SD card utilizes the SD-MMC module. The connection between the hardware of the data

logger and the computer-based user interface device is established through serial communication via the USB port. The schematic diagram of the electronic system of the data logger can be seen in Figure 2. Meanwhile, the layout design of the connections in the data logger casing can be observed in Figure 3.

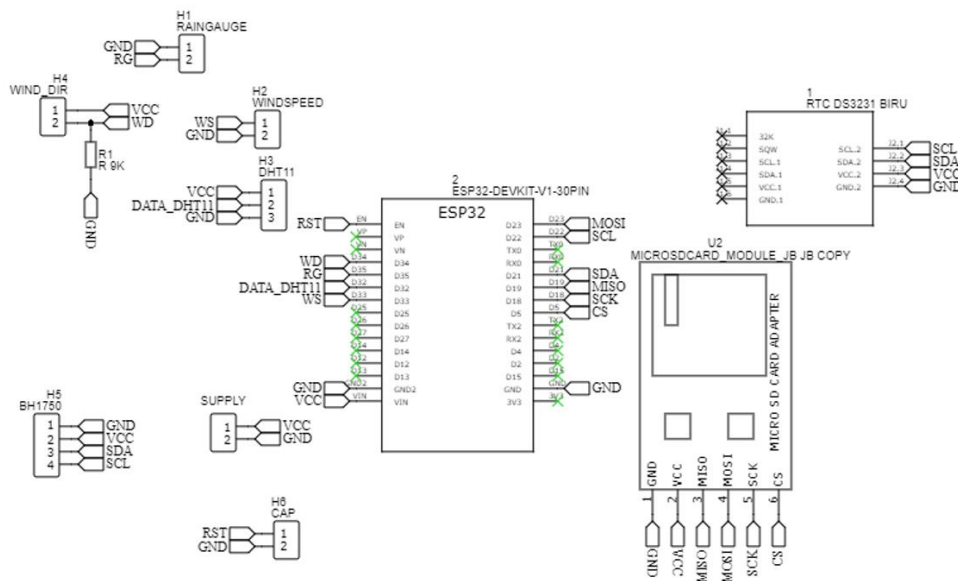

Figure 2. Schematic diagram.

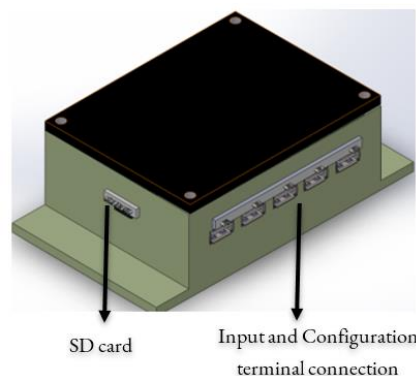

Figure 3. Design layout on the data logger module.

In addition to hardware design, software design is also carried out. The presence of configuration features through the user interface of the computer device requires a specific technique to ensure that the processing performed by the processor aligns with the configuration results. The challenge faced is how to design the system in the user interface application built using Visual Basic so that it can connect with ESP32. Additionally, how to design ESP32 to read the configuration results performed through the user interface device. Data acquisition processing on the ESP32 processor is carried out after the configuration process is completed. The configuration results data from the user interface sent serially to ESP32 are stored in the EEPROM of the ESP32 module. After the data in the EEPROM is successfully read, the data acquisition process from the sensors is then carried out. The program flow on the ESP32 can be seen in Figure 4.

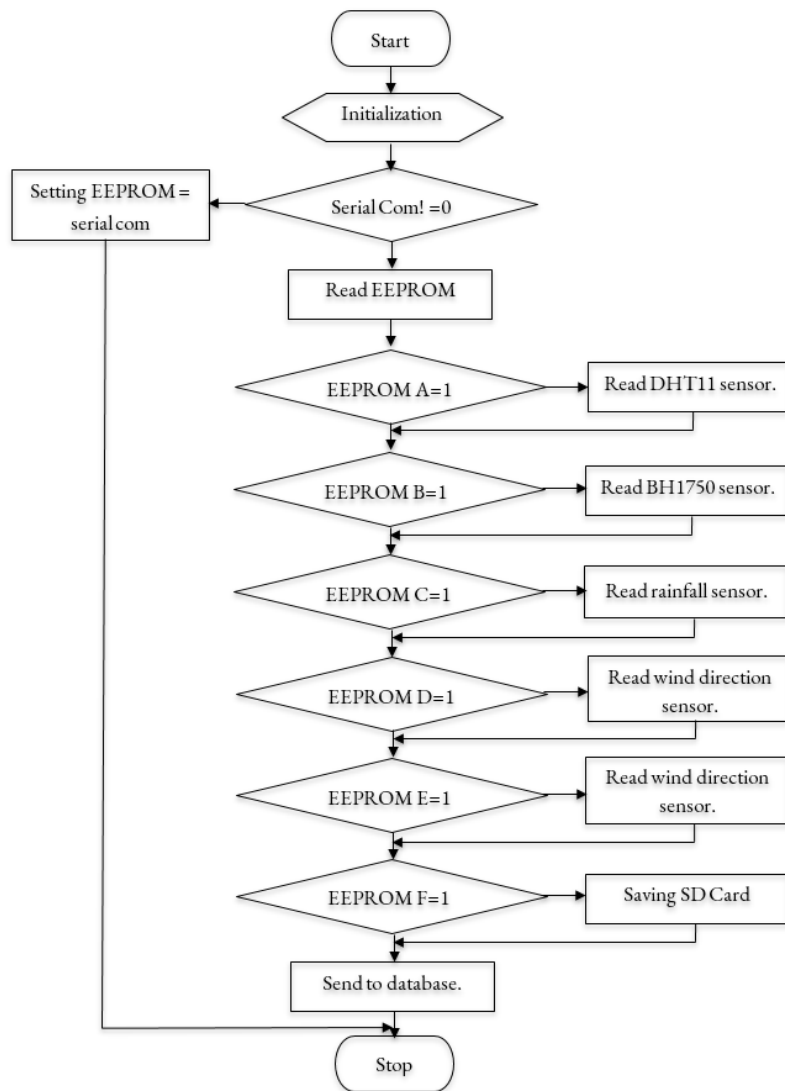

Figure 4. Flowchart ESP32.

3. Result and Discussion

The hardware display of the dynamic multi-sensor and multi-storage data logger can be seen in Figure 5. In the image, you can observe the presence of input terminals and an SD card slot, which align with the design. The data logger is then connected to the sensor inputs, and configuration is carried out.



Figure 1. Hardware of data logger.

In the dynamic multi-sensor and multi-storage data logger, the first step is the configuration process on the user interface via a computer. The software used to build the user interface is Visual Basic. In

the user interface, there are several features, including the selection of sensor inputs, storage mode selection, and configuration of the connection to the database. The initial display on the user interface can be seen in Figure 6a.

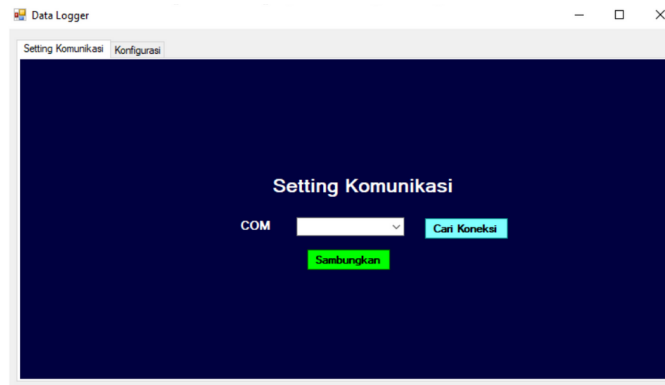

a. Communication Setting Connection

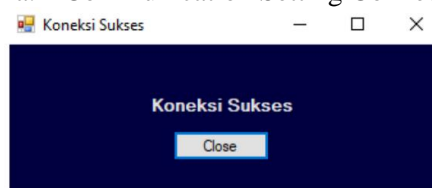

b. Success Connection Pop Up

Figure 2. Communication Setting Windows

In the image, you can see the display of the process of setting the COM selection for connecting the computer to the ESP32. After running the application and connecting the computer and ESP32 via a USB cable, the connection setup process can begin. The steps involve pressing the "Cari Koneksi" (Search Connection) button. After the COM text box is filled, it means that the COM on the ESP32 has been detected. The next process is to press the "Sambungkan" (Connect) button to establish the connection between the user interface application and the ESP32. When the connection process is successful, a pop-up display will appear, as shown in Figure 6b.

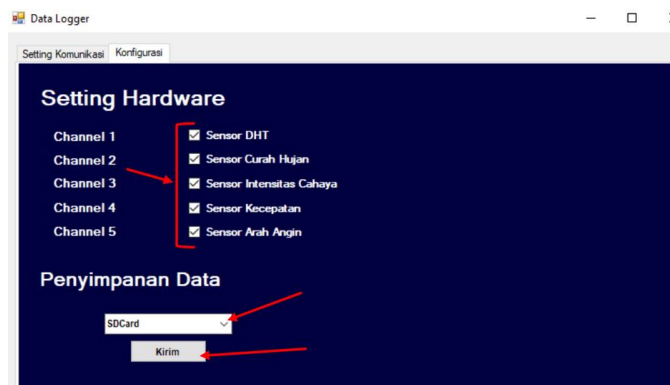

a. Configuration Menu

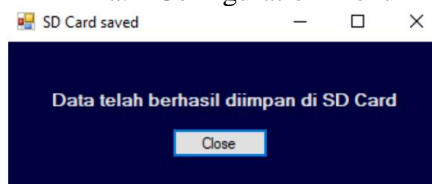

b. SD Card Saved Pop up

Figure 3. Configuration Setting Window

After a successful connection, the next step is to undergo the configuration process. The configuration process involves selecting the input sensors to be connected and the storage media. The configuration menu display can be seen in Figure 7a. In the configuration display, there will be 5 types

of input sensors and also data storage media in the form of SD card and Cloud. Sensor selection is done by checking the checkbox for the sensors to be used. After selecting the types of input sensors, the next process is to choose the storage media. If "SD card" is selected and then clicked on "Kirim" (Send), a pop-up like in Figure 7b will appear, indicating that the storage process will be carried out on the SD card, and the data will be saved in .csv format.

Meanwhile, if "Cloud" is chosen, it will proceed to the "Setting Koneksi" (Connection Setting) with a display as shown in Figure 8a. In that menu, there are settings for SSID and password, as seen in Figure 8b. Both settings refer to the Wi-Fi network that will be used for sending data to the cloud. The existence of this menu makes the system more dynamic because it is not dependent on just one Wi-Fi source. In addition to the connection settings, the next menu is "Setting Database," which involves entering the URL address of the database where the data will be stored. After the connection and database settings are complete, clicking the "Kirim" (Send) menu will save the data to the database. The display of the data stored in the MySQL database can be seen in Figure 9.

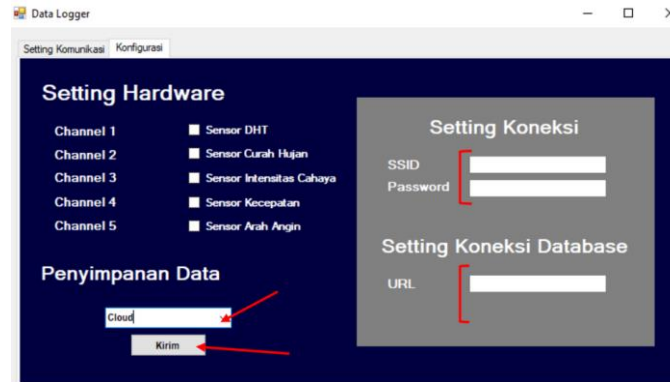

a. Setting Connection for Cloud Storage Menu

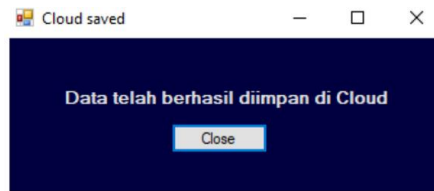

b. Cloud Saved Pop Up

Figure 4. Connection setting window.

The screenshot shows the phpMyAdmin interface for a database named 'cuaca_monitoring_cuaca_kel6'. The 'Data Logger' table is selected, displaying a list of 19 records. Each record includes an ID, a timestamp, and various weather metrics.

Opsil	Id	Waktu	Suhu	Kelembapan	Kecepatan_Angin	Arah_Angin	Curah_Hujan	Intensitas_Cahaya
Ubah Salin Hapus	1	2023-08-01 16:11:29	37	43	0	TL - 45	26	33
Ubah Salin Hapus	2	2023-08-01 16:11:49	37	49	0	TL - 45	7	30
Ubah Salin Hapus	3	2023-08-01 16:12:08	33	54	0	UTL - 22	33	33
Ubah Salin Hapus	4	2023-08-01 16:12:27	37	57	0	SBD - 202	15	36
Ubah Salin Hapus	5	2023-08-01 16:12:47	35	48	0	UTL - 22	33	24
Ubah Salin Hapus	6	2023-08-01 16:13:06	34	44	0	Selatan - 180	13	39
Ubah Salin Hapus	7	2023-08-01 16:13:25	38	58	0	SBD - 202	14	27
Ubah Salin Hapus	8	2023-08-01 16:14:20	36	51	26	BBD - 247	42	27
Ubah Salin Hapus	9	2023-08-01 16:14:40	38	59	23	UTL - 22	47	31
Ubah Salin Hapus	10	2023-08-01 16:14:59	33	45	24	Selatan - 180	6	32
Ubah Salin Hapus	11	2023-08-01 16:15:18	33	51	23	SBD - 202	46	26
Ubah Salin Hapus	12	2023-08-01 16:15:59	34	56	25	SBD - 202	44	32
Ubah Salin Hapus	13	2023-08-01 16:16:18	32	43	26	TL - 45	31	24
Ubah Salin Hapus	14	2023-08-01 16:16:38	35	50	23	T - 90	25	35
Ubah Salin Hapus	15	2023-08-01 16:16:57	35	55	23	STG - 157	36	24
Ubah Salin Hapus	16	2023-08-01 16:17:16	33	58	24	Selatan - 180	12	38
Ubah Salin Hapus	17	2023-08-01 16:17:30	33	57	23	SBD - 202	41	28
Ubah Salin Hapus	18	2023-08-01 16:17:50	33	49	24	SBD - 202	31	34
Ubah Salin Hapus	19	2023-08-01 16:18:09	39	52	25	TL - 45	45	29

Figure 5. Data in database system.

The results of testing the menus in "Setting Komunikasi" (Communication Setting) and "Konfigurasi" (Configuration) menus show that all menu function properly. Challenges in the communication setting process usually only occur when the cable connecting the computer to the hardware is not perfectly connected. Meanwhile, issues experienced in the configuration menu typically arise when configuring connections due to Wi-Fi networks not being captured effectively.

4. Conclusion

Dynamic multi-sensor and multi-storage data loggers feature the selection of input sensors and data storage media. The selection process is carried out through a computer-based user interface. The challenges involved include designing the system in a user interface application built using Visual Basic to connect with the ESP32. Additionally, it is necessary to design the ESP32 to read the configuration results performed through the user interface. Communication between the computer-based user interface application and the ESP32 is conducted through serial communication. The overall testing results of the data logger indicate that all configuration features in the system have functioned properly.

Acknowledgement

Thank you to Politeknik Caltex Riau for providing funding assistance for the implementation of this research through the Internal Grant Research Scheme in 2023.

References

- Ali, A. S., Zanzinger, Z., Debose, D., & Stephens, B. (2016). Open Source Building Science Sensors (OSBSS): A low-cost Arduino-based platform for long-term indoor environmental data collection. *Building and Environment*, *100*, 114–126. <https://doi.org/10.1016/j.buildenv.2016.02.010>
- Bayhan, A. Y., Turhan, C., Bayhan, A. Y., & Turhan, C. (2021). Development of a solar-based temperature and relative humidity data logger Science Literature TM Development of a solar-based temperature and relative humidity data logger. In *Turkish Journal of Electromechanics and Energy* (Vol. 6, Issue 1). <https://www.scienceliterature.com>.
- Bhadola, P., Kunakhonnuruk, B., Kongbangkerd, A., & Gupta, Y. M. (2022). Analysis of Microenvironment Data Using Low-Cost Portable Data Logger Based on a Microcontroller. *ECS Transactions*, *107*(1), 15099–15109. <https://doi.org/10.1149/10701.15099ecst>
- Clement, R., Fargier, Y., Dubois, V., Gance, J., Gros, E., & Forquet, N. (2020). OhmPi: An open source data logger for dedicated applications of electrical resistivity imaging at the small and laboratory scale. *HardwareX*, *8*. <https://doi.org/10.1016/j.ohx.2020.e00122>.
- Curasi, S. R., Klupar, I., Loranty, M. M., & Rocha, A. V. (2022). An open-source, durable, and low-cost alternative to commercially available soil temperature data loggers. *Sensors*, *22*(1). <https://doi.org/10.3390/s22010148>
- Irfan Bin Edi, M. E., Emileen Abd Rashid, N., Ismail, N. N., & Cengiz, K. (2022). Low-Cost, Long-Range Unmanned Aerial Vehicle (UAV) Data Logger Using Long Range (LoRa) Module. *IEEE Symposium on Wireless Technology and Applications, ISWTA, 2022-August*, 22–28. <https://doi.org/10.1109/ISWTA55313.2022.9942751>.
- Mabrouki, J., Azrou, M., Dhiba, D., Farhaoui, Y., & Hajjaji, S. El. (2021). IoT-based data logger for weather monitoring using arduino-based wireless sensor networks with remote graphical application and alerts. *Big Data Mining and Analytics*, *4*(1), 25–32. <https://doi.org/10.26599/BDMA.2020.9020018>.
- Mahzan, N. N., Omar, A. M., Rimon, L., Noor, S. Z. M., & Rosselan, M. Z. (2017). Design and development of an arduino based data logger for photovoltaic monitoring system. *International Journal of Simulation: Systems, Science and Technology*, *17*(41), 15.1-15.5. <https://doi.org/10.5013/IJSSST.a.17.41.15>.
- Matkar, C., Shrivastav, Y., Chavhan, D., Nale, G., Rangari, E. A., Electrical Engineering, B., & Professor, A. (2022). Arduino Based Data Logger. In *International Journal of Research Publication and Reviews Journal homepage: www.ijrpr.com* (Vol. 3, Issue 5). www.ijrpr.com.
- Pasquali, V., D'Alessandro, G., Gualtieri, R., & Leccese, F. (2017). A new data logger based on Raspberry-Pi for Arctic Notostraca locomotion investigations. *Measurement: Journal of the International Measurement Confederation*, *110*, 249–256. <https://doi.org/10.1016/j.measurement.2017.07.004>.
- Sadli, M. (2020). Desain Data Logger Sensor Suhu Berbasis Mikrokontroler Atmega16 Dengan Empat Kanal Input (Vol. 17, Issue 1).
- Samkria, R., Abd-Elnaby, M., Singh, R., Gehlot, A., Rashid, M., Aly, M. H., & El-Shafai, W. (2021). Automatic PV Grid Fault Detection System with IoT and LabVIEW as Data Logger. *Computers, Materials and Continua*, *69*(2), 1709–1723. <https://doi.org/10.32604/cmc.2021.018525>.

- Singh, T., & Thakur, R. (2019). Design and Development of PV Solar Panel Data Logger. *International Journal of Computer Sciences and Engineering*, 7(4), 364–369. <https://doi.org/10.26438/ijcse/v7i4.364369>.
- Spinelli, G. M., & Gottesman, Z. L. (2019). A low-cost Arduino-based datalogger with cellular modem and FTP communication for irrigation water use monitoring to enable access to CropManage. *HardwareX*, 6. <https://doi.org/10.1016/j.ohx.2019.e00066>.
- Yadav, A., & Sakle, N. (2023). Development of low-cost data logger system for capturing transmission parameters of two-wheeler using Arduino. *Materials Today: Proceedings*, 72, 1697–1703. <https://doi.org/10.1016/j.matpr.2022.09.471>.